



MARCH PUMPS

1819 PICKWICK AVE., GLENVIEW, IL 60026-1306, U.S.A
PHONE: (847) 729-5300 - FAX: (847) 729-7062
WWW.MARCHPUMP.COM

“MAGNE-BOOST”[®] HOT WATER PUMP MODEL 821 SERIES PUMP INSTALLATION INSTRUCTIONS, SERVICE AND REPAIR PARTS LIST



MODEL
821-BR-T
821-CI-T



MODEL
821-BR
821-CI

SPECIFICATIONS:	
INLET AND OUTLET:	Flanged or threaded
ELECTRICAL:	115 Volts, 60 Hz, 1 Phase, 110 Watts, 1.8 AMP, 1600 RPM
MAXIMUM LIQUID TEMPERATURE:	250°F
MAXIMUM INTERNAL PRESSURE:	150 PSI
CONSTRUCTION	Stainless Steel, Ryton® Plastic, Cast Iron or Bronze, Ceramic, and Nitrile/Fibre
DIMENSIONS:	Height over Flanges, 6-5/16" Width 4-3/4" Length 9-11/16"
CAPACITY:	22 GPM at 1 Ft. Shut Off at 8 Ft.
APPROVAL:	Pumps are recognized under the component program of Underwriters Laboratories Inc. File E80954*

* UL Recognition on pumps, file E80954, is for water only.
Contact the factory for applications other than those listed, and for liquids other than water.

INSTALLATION: The Model 821 pump is assembled and ready for installation. The pump should be mounted with the Electric Conduit Box on the bottom. The oil ports will then be on the top of the motor. The pump housing should be installed with the arrow pointing in the direction of the water flow within the system. If the arrow indicating water flow is not in the direction you require when the motor is in position, remove the four housing screws (Item 11) holding the housing to the motor assembly, and rotate the housing assembly as required. Replace the four screws and tighten.

The pump is made up of two basic sub-assemblies. They are the Pump Volute and Impeller Assembly (Item 1 thru 7); and the Drive Magnet, Bracket and Motor Assembly (Item 8, 9, & 12). To separate the 2 assemblies, simply remove the screws (Item 11). The pump will then separate into the 2 sub-assemblies. The water will still be contained within the pump volute assembly unless you loosen the housing screws (Item 13) on the rear of the volute assembly.

DESCRIPTION: Your March hot water booster pump is a non-self priming unit built to handle liquid transfer in heating and cooling operations. Applications include home heating systems, solar heating systems, heat recovery systems and re-circulating water in domestic and commercial hot water tanks.

GENERAL SAFETY INFORMATION: Follow all local electrical and safety codes, and the Occupational Safety and Health Act (OSHA). Make certain that the power source conforms to the requirements of your equipment. Always disconnect power source before performing any work on or near the electric motor. Caution must be exercised to relieve any pressure in the system and in draining hot water from the pump or the system.

LUBRICATION: The motor should be oiled at least once a year at the start of the heating season with 4 or 5 drops of SAE 20 weight non-detergent oil in each bearing. If the pump is used daily, it should be oiled every six months. Do not over oil. No oiling is required on ball bearing motors.

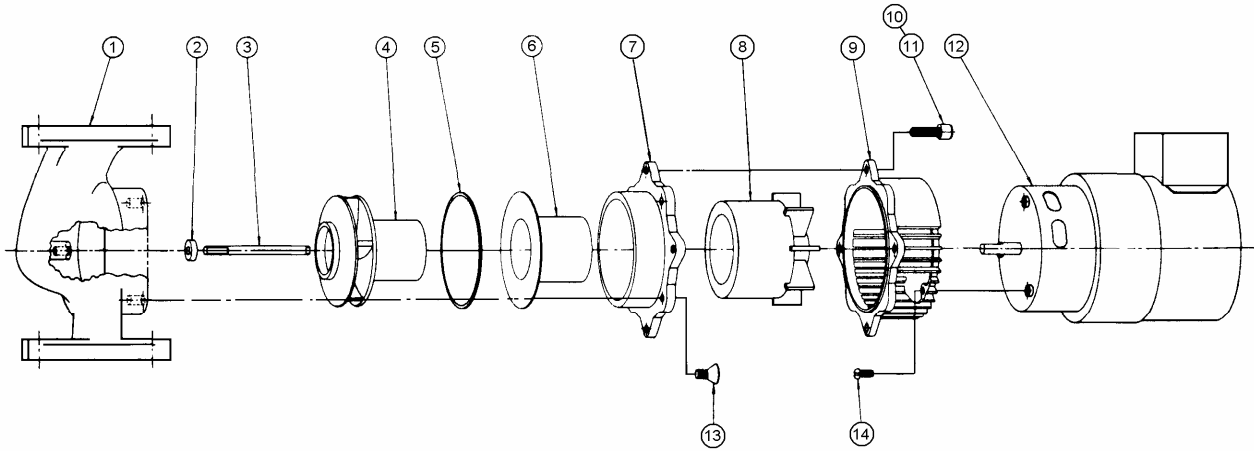

REPAIR PARTS LIST			
ITEM	DESCRIPTION	QTY.	PART NUMBER
1	Pump Housing, Flanged, Cast Iron	1	0821-0025-0000
	Pump Housing, Flanged, Bronze		0821-0064-0000
	Pump Housing, ¾" Threaded, Bronze		0821-0075-0000
	Pump Housing, ¾" Threaded, Cast Iron		0821-0080-0000
2	Thrust Washer, Ceramic	1	0821-0079-1000
3	Impeller Shaft, 316 Stainless	1	0821-0036-1000
4	Impeller Magnet Assembly	1	0821-0023-0200
5	Gasket	1	0804-0050-1000
6	Impeller Magnet Housing	1	0821-0035-0100
7	Housing Connecting Ring	1	0821-0044-0000
8	Drive Magnet Assembly	1	0821-0086-0100
9	Motor To Pump Connecting Bracket	1	0821-0104-1000
10	¼" Flat Washer	4	0155-0021-1000
11	¼-20 Soc. Hd. Screw	4	0804-0052-1000
12	Motor, 115 Volt	1	0821-0084-1000
	Motor, 230 Volt		0821-0088-1000
13	¼-20 Flat Hd. Housing Screw	4	1043-0009-1000
14	#8-32 Rd. Hd. Motor Screw	4	0210-0028-1000
	Flanges available in ¾", 1", 1¼", and 1½" pipe sizes. Specify size and steel or bronze.		
	Flange Gaskets, for Pump Housing with Flat Flanges	2	0821-0105-1000
	Flange Bolts	4	0804-0054-1000
	Flanges Nuts	4	0804-0055-1000

DISASSEMBLY AND REASSEMBLY:

1 – The motor assembly (Items 8, 9, & 12) can be removed from the pump housing assembly (Items 1 thru 7) without having to drain the liquid out of the system.

2 – Remove four screws (Item 11) and slide the motor assembly away from the pump housing assembly.

3 – If you must replace parts inside the pump housing assembly, then first close off the valves that supply water to the heating system or to the hot water tank. Drain the system to relieve any pressure.

4 – After the system is drained and cool enough to handle, then remove the four screws (Item 13) on the rear of the housing.

5 – The Impeller magnet housing (Item 6) and the housing connecting ring (Item 7) can now be removed. It may be a snug fit into the pump housing and it may be necessary to pry evenly under the four ears to loosen it.

6 – Remaining pump parts can now be lifted out in sequence as shown on the exploded view. Replace any worn or damaged parts. Replace the gasket (Item 5) anytime the impeller magnet housing is removed.

LIMITED WARRANTY

March pumps are guaranteed only against defects in workmanship or materials for a period of one year from date of manufacture pumping water. On all other solutions, contact the factory for application assistance. March Pump Application Worksheet 750-130-10 is available for additional warranty information.



1819 PICKWICK AVE., GLENVIEW, IL 60026-1306, U.S.A
 PHONE: (847) 729-5300 · FAX: (847) 729-7062 · www.marchpump.com

0821-0063-1000 R9